

CONFIDENTIAL

THIS DOCUMENT AND INFORMATION CONTAINED HEREIN IS PROPRIETARY AND CONFIDENTIAL TO PRECOR STRENGTH INCORPORATED. RECIPIENTS OF THIS DOCUMENT AGREE THAT THIS DOCUMENT AND INFORMATION WILL NOT BE USED FOR ANY PURPOSE, REPRODUCED OR COPIED, OR DISCLOSED TO ANY THIRD PARTY, EITHER IN WHOLE OR IN PART WITHOUT PRIOR EXPRESS WRITTEN PERMISSION OF PRECOR STRENGTH, INCORPORATED.

PRECOR USA
PRECOR STRENGTH, INC.

28936 AVE WILLIAMS
VALENCIA, CA 91355
TELEPHONE: 661-362-0300

SIGN IN BLUE OR BLACK INK ONLY		UNLESS OTHERWISE SPECIFIED: DIMENSIONS ARE IN INCHES	
DRWN BY	01.02.07	MGP	TOLERANCES ARE:
DWG CHK			LIN .X=±0.1 .XXX=±0.010
ENG	01.02.07	RSG	LIN .XX=±0.02 .XXXX=±0.0001
MFG ENG			ANGULAR: ±1.0°
CS			ALL DIMS AFTER PLATING
QA			BREAK ALL SHARP EDGES
ID			REMOVE ALL BURRS
REG			ALL ANGLES & BENDS 90°
			DWG PER ASME Y14.5M-1994
			DO NOT SCALE DRAWING
			ALL MACHINED SURFACES

PRODUCT: **STRENGTH**

ASSEMBLY CONNECTION, 10.5, W/ 1 PULLEY HSG

DWG. NO.	SUBREV
CW31868-402	A

SIZE	PAGE	OF
C	1	1

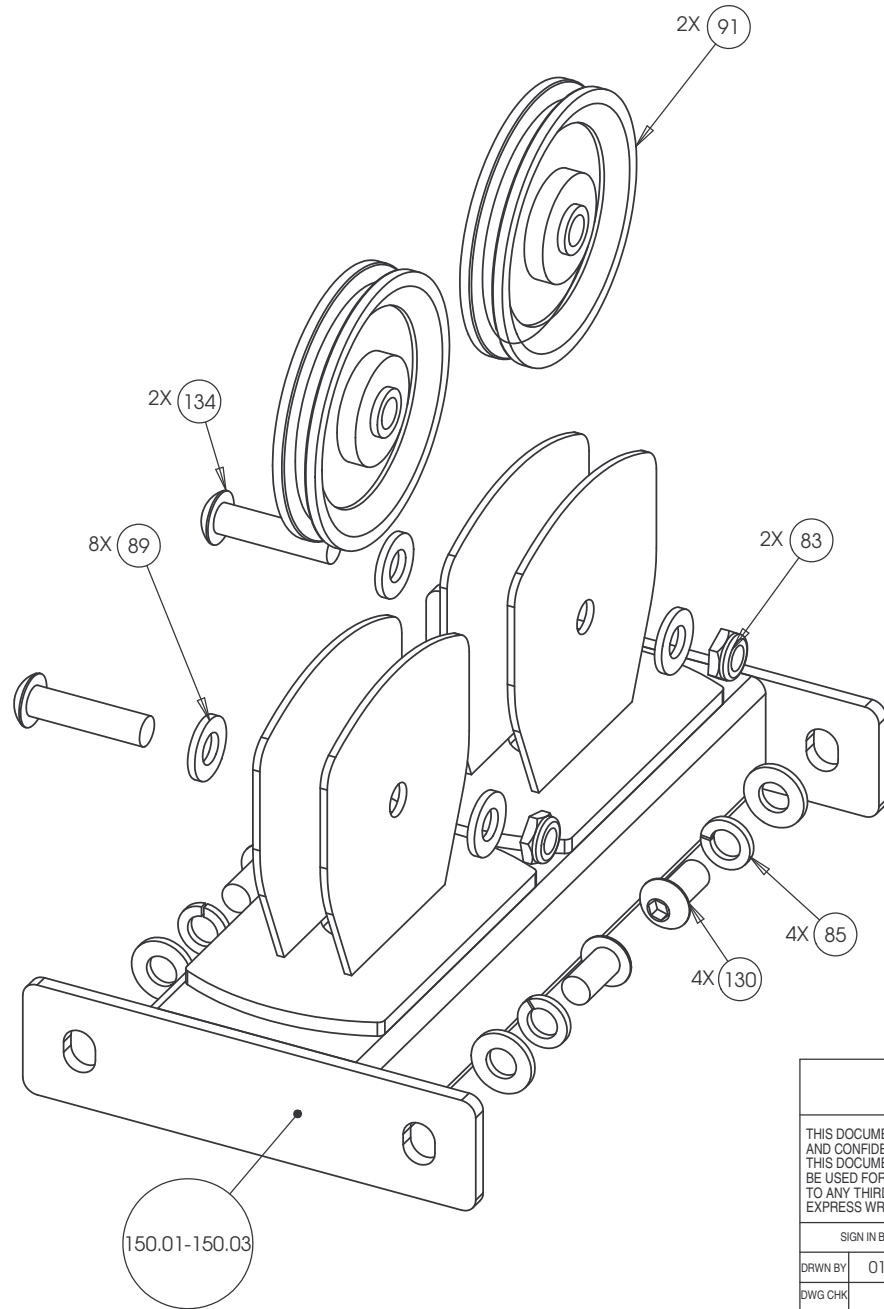

CONFIDENTIAL

THIS DOCUMENT AND INFORMATION CONTAINED HEREIN IS PROPRIETARY AND CONFIDENTIAL TO PRECOR STRENGTH INCORPORATED. RECIPIENTS OF THIS DOCUMENT AGREE THAT THIS DOCUMENT AND INFORMATION WILL NOT BE USED FOR ANY PURPOSE, REPRODUCED OR COPIED, OR DISCLOSED TO ANY THIRD PARTY, EITHER IN WHOLE OR IN PART WITHOUT PRIOR EXPRESS WRITTEN PERMISSION OF PRECOR STRENGTH, INCORPORATED.

PRECOR USA
PRECOR STRENGTH, INC.

28936 AVE WILLIAMS
VALENCIA, CA 91355
TELEPHONE: 661-362-0300

SIGN IN BLUE OR BLACK INK ONLY		UNLESS OTHERWISE SPECIFIED: DIMENSIONS ARE IN INCHES	
DRWN BY	01.02.07	MGP	TOLERANCES ARE:
DWG CHK			LIN .X=±0.1 .XXX=±0.010
ENG	01.02.07	RSG	LIN .XX=±0.02 .XXXX=±0.0001
MFG ENG			ANGULAR: ±1.0°
CS			ALL DIMS AFTER PLATING
QA			BREAK ALL SHARP EDGES
ID			REMOVE ALL BURRS
REG			ALL ANGLES & BENDS 90°
			DWG PER ASME Y14.5M-1994
			DO NOT SCALE DRAWING
			ALL MACHINED SURFACES
			SIZE PAGE OF
			C 1 1

PRODUCT:	STRENGTH
ASSEMBLY CONNECTION, 13.75, W/ 2 PULLEY HSG	
DWG. NO.	CW31876-402
SUBREV	A

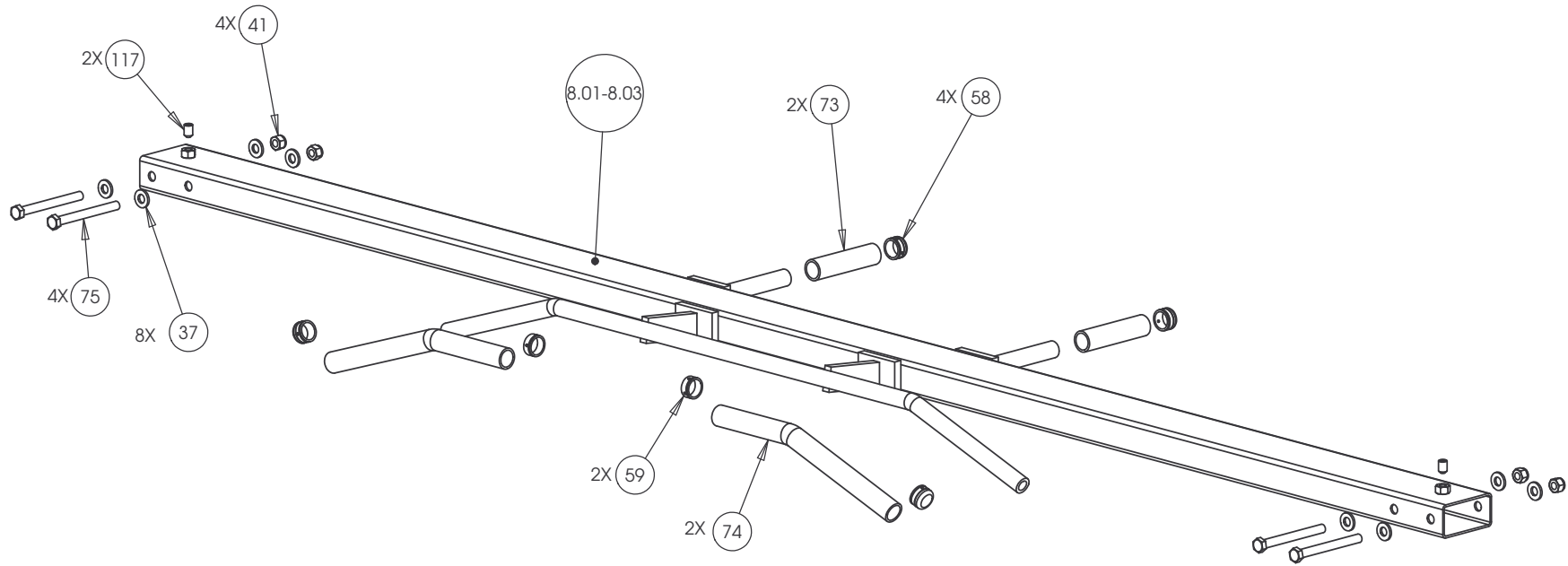

CONFIDENTIAL

THIS DOCUMENT AND INFORMATION CONTAINED HEREIN IS PROPRIETARY AND CONFIDENTIAL TO PRECOR STRENGTH INCORPORATED. RECIPIENTS OF THIS DOCUMENT AGREE THAT THIS DOCUMENT AND INFORMATION WILL NOT BE USED FOR ANY PURPOSE, REPRODUCED OR COPIED, OR DISCLOSED TO ANY THIRD PARTY, EITHER IN WHOLE OR IN PART WITHOUT PRIOR EXPRESS WRITTEN PERMISSION OF PRECOR STRENGTH, INCORPORATED.

PRECOR USA
PRECOR STRENGTH, INC.

28936 AVE WILLIAMS
VALENCIA, CA 91355
TELEPHONE: 661-362-0300

SIGN IN BLUE OR BLACK INK ONLY		UNLESS OTHERWISE SPECIFIED: DIMENSIONS ARE IN INCHES TOLERANCES ARE: LIN .X=±0.1 .XXX=±0.010 LIN .XX=±0.02 .XXXX=±0.0001 ANGULAR: ±1.0° ALL DIMS AFTER PLATING BREAK ALL SHARP EDGES REMOVE ALL BURRS ALL ANGLES & BENDS 90° DWG PER ASME Y14.5M-1994 DO NOT SCALE DRAWING ALL MACHINED SURFACES	
DRWN BY	01.02.07	MGP	
DWG CHK			
ENG	01.02.07	RSG	
MFG ENG			
CS			
QA			
ID			
REG			
	SIZE	PAGE	OF
	C	1	1

PRODUCT:	STRENGTH
ASSEMBLY CONNECTION, 107 IN, CROSSBEAM W-HANDLES	
DWG. NO.	CW31878-401
SUBREV	A

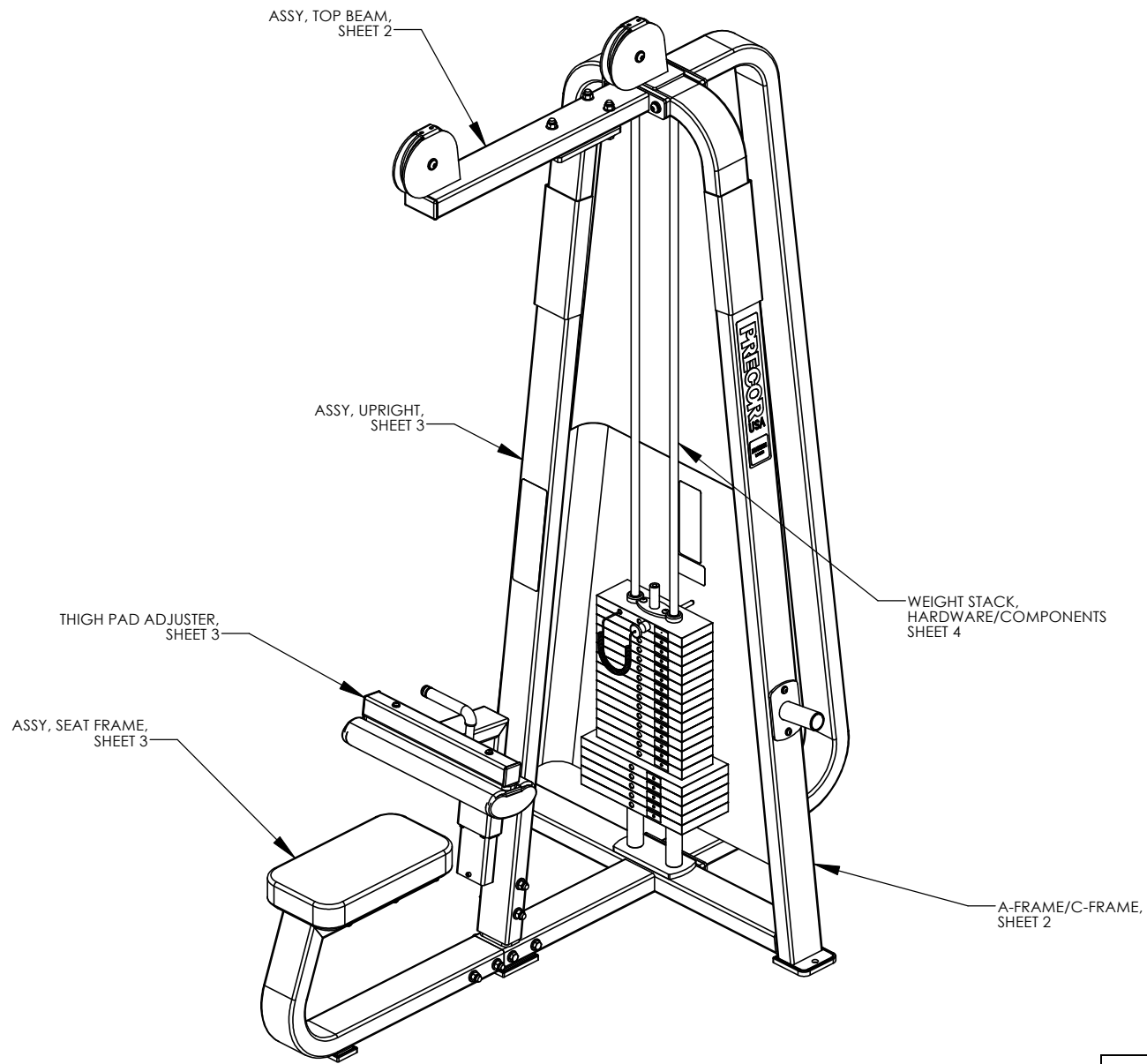

P/N: CW31932-402	SUBREV: C
DRAWN BY: JEC	DATE: 09.11.08
SHEET 1 OF 4	

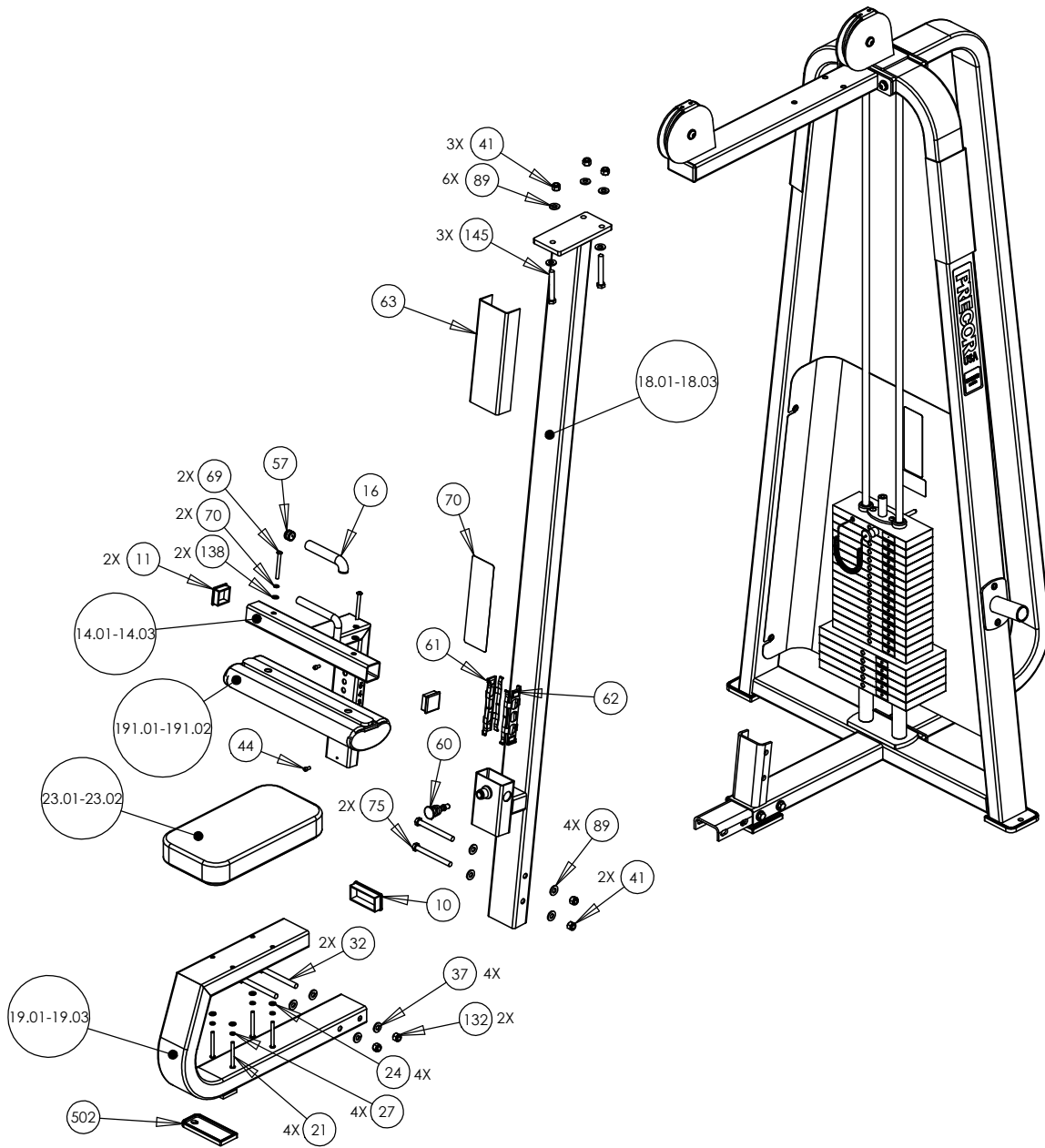

P/N: CW31932-402	SUBREV: C
DRAWN BY: JEC	DATE: 09.11.08
SHEET 3 OF 4	

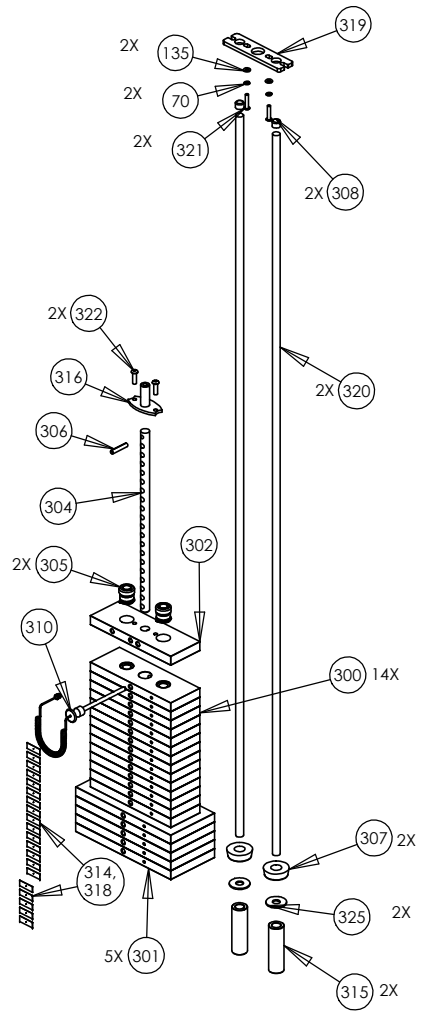
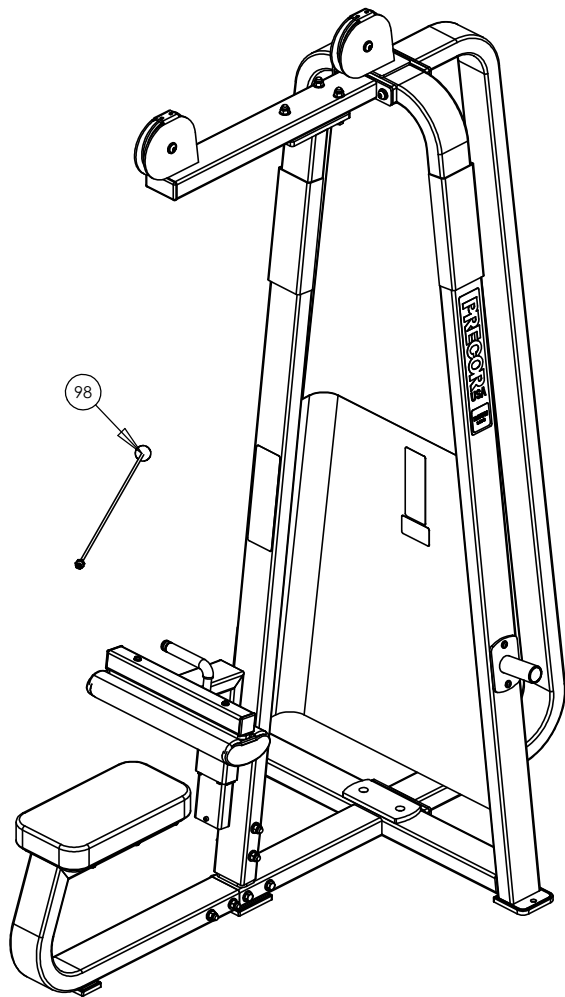

P/N: CW31932-402		SUBREV: C
DRAWN BY: JEC	DATE: 09.11.08	SHEET 4 OF 4

ASSY, FRAME, MAIN
PAGE 2

WEIGHT STACK,
HARDWARE/ COMPONENTS
PAGE 3

HARDWARE/COMPONENTS,
PAGE 2

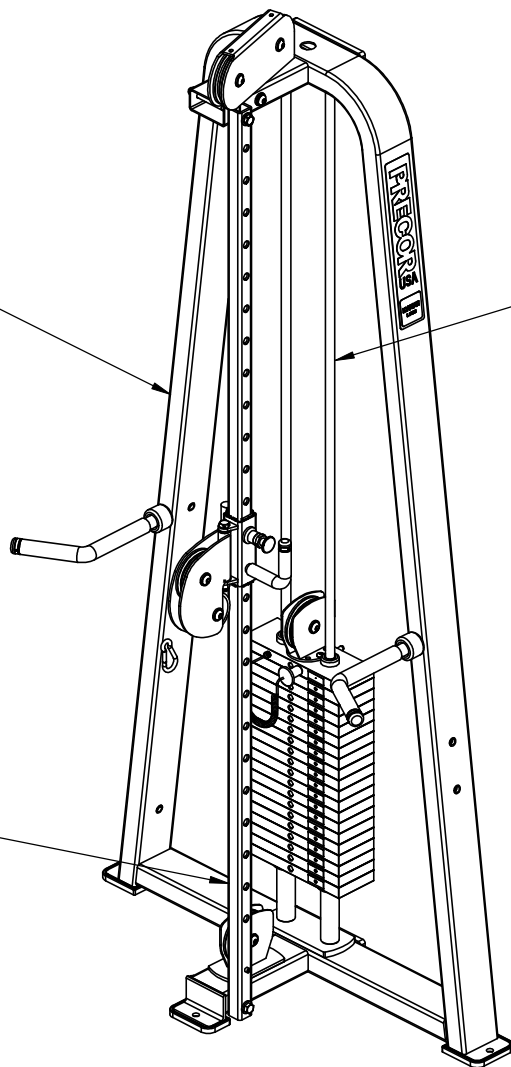

P/N: CW34920-401	SUBREV: A
DRAWN BY: VLE	DATE: 06.24.09
	SHEET 1 OF 3

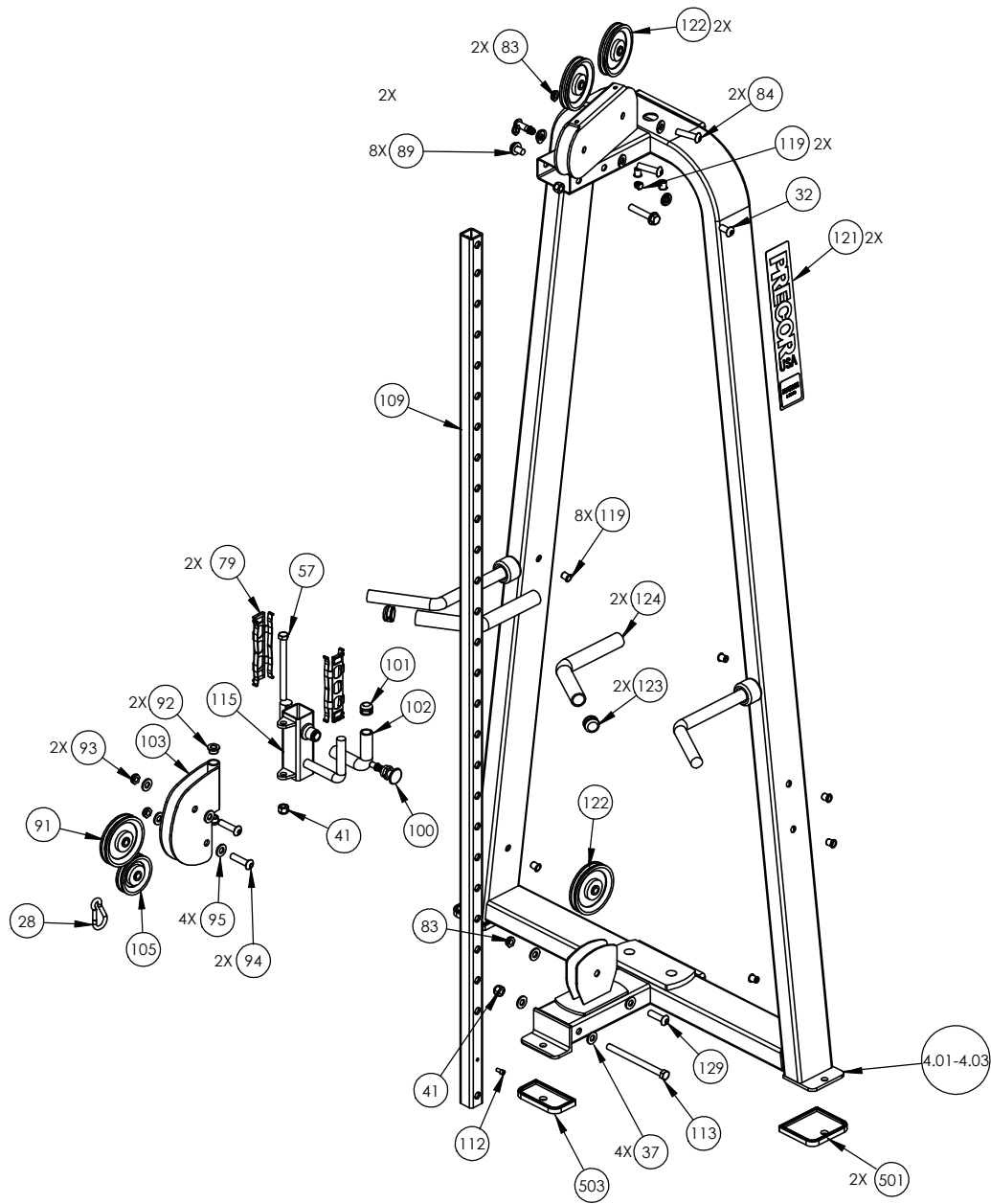

P/N: CW34920-401	SUBREV: A
DRAWN BY: VLE	DATE: 06.24.09
SHEET 2 OF 3	

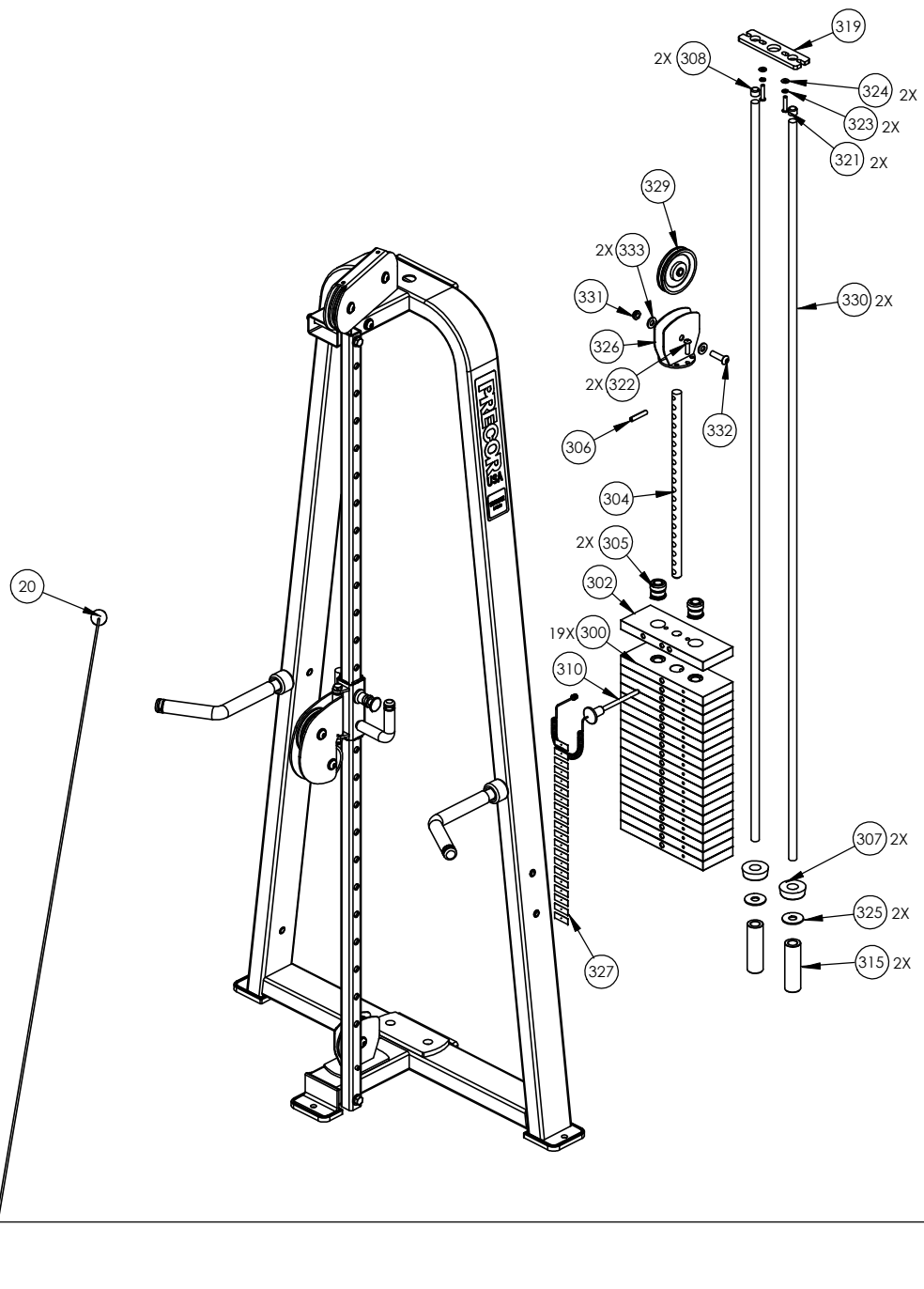

P/N: CW34920-401	SUBREV: A
DRAWN BY: VLE	DATE: 06.24.09
SHEET 3 OF 3	

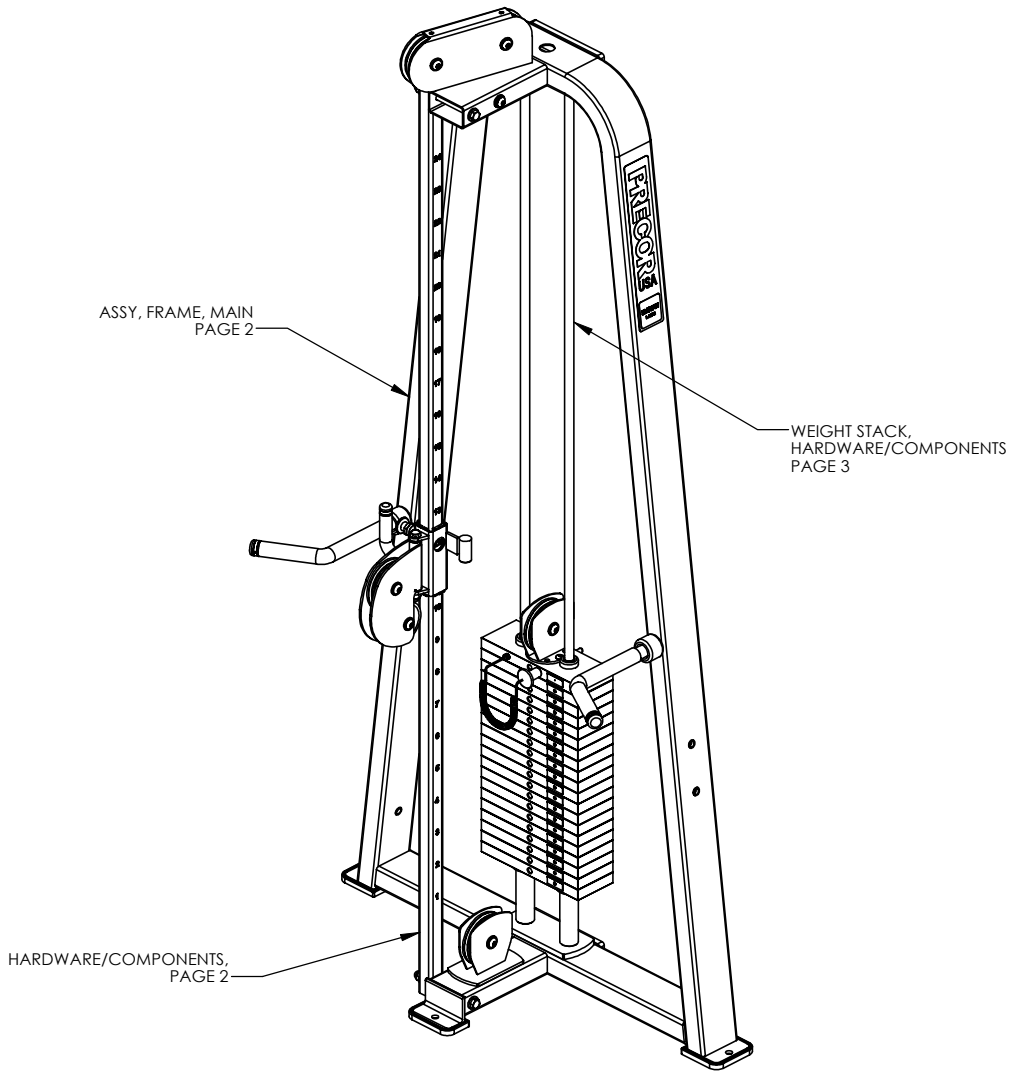

P/N: CW34921-401	SUBREV: A
DRAWN BY: VLE	DATE: 06.24.09
SHEET 1 OF 3	

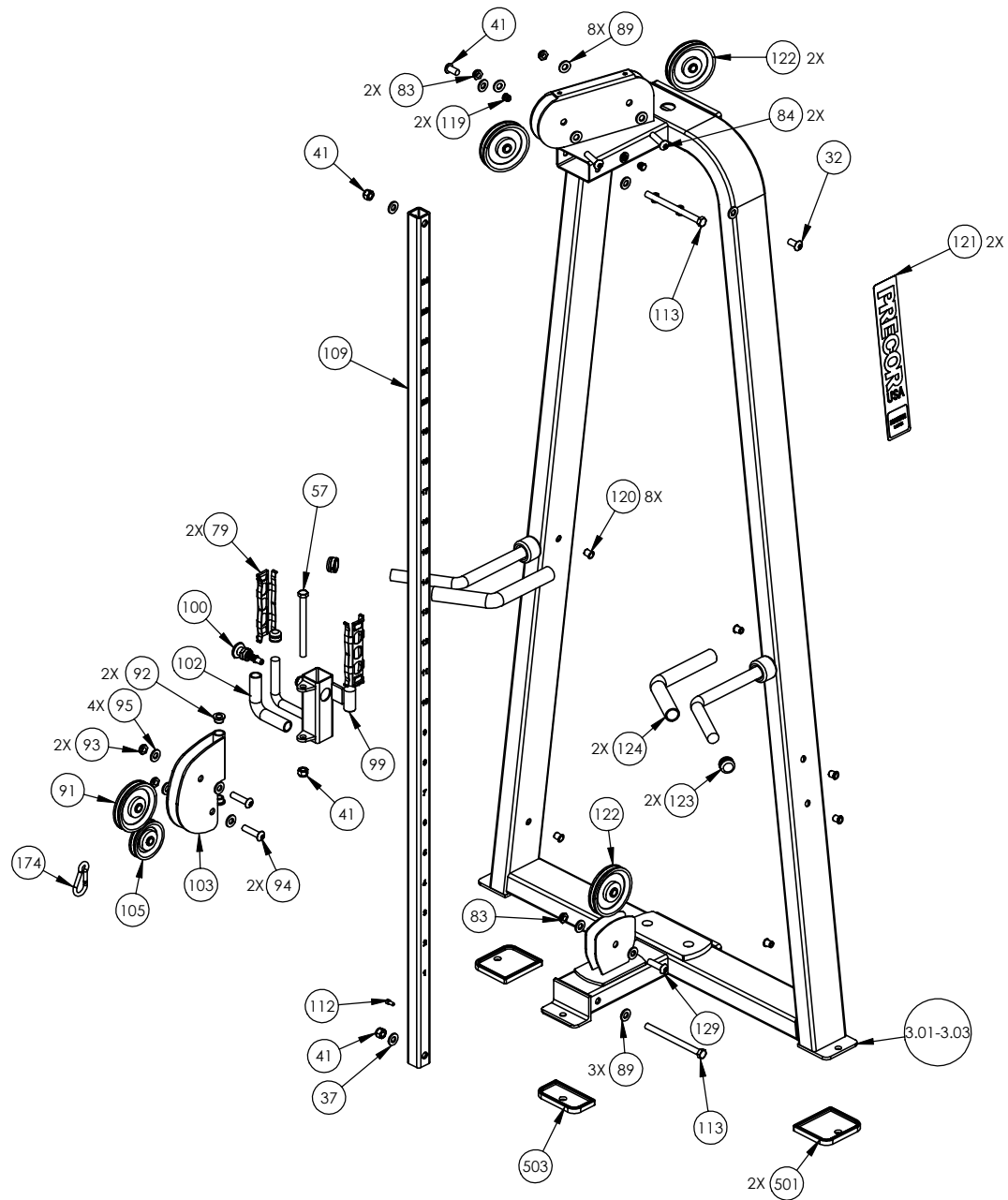

P/N: CW34921-401		SUBREV: A
DRAWN BY: VLE	DATE: 06.24.09	SHEET 2 OF 3

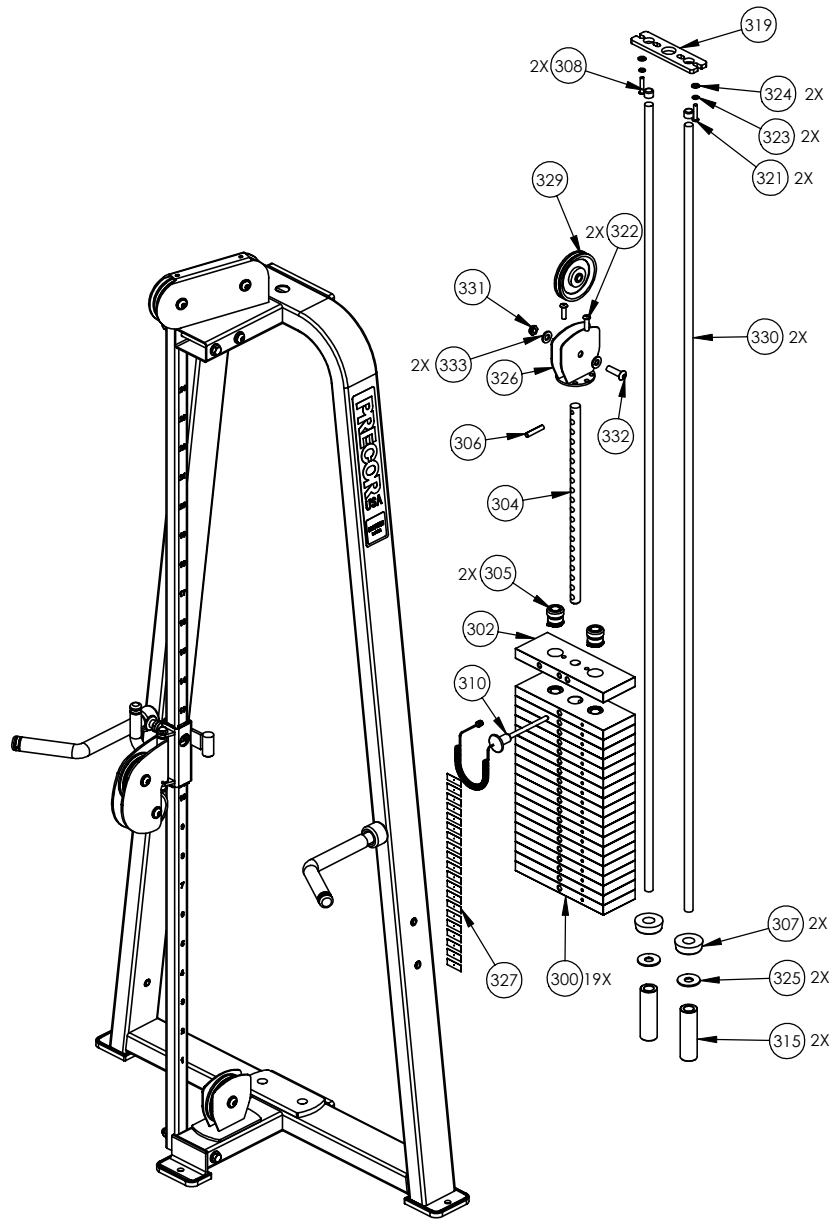

P/N: CW34921-401	SUBREV: A
DRAWN BY: VLE	DATE: 06.24.09
SHEET 3 OF 3	

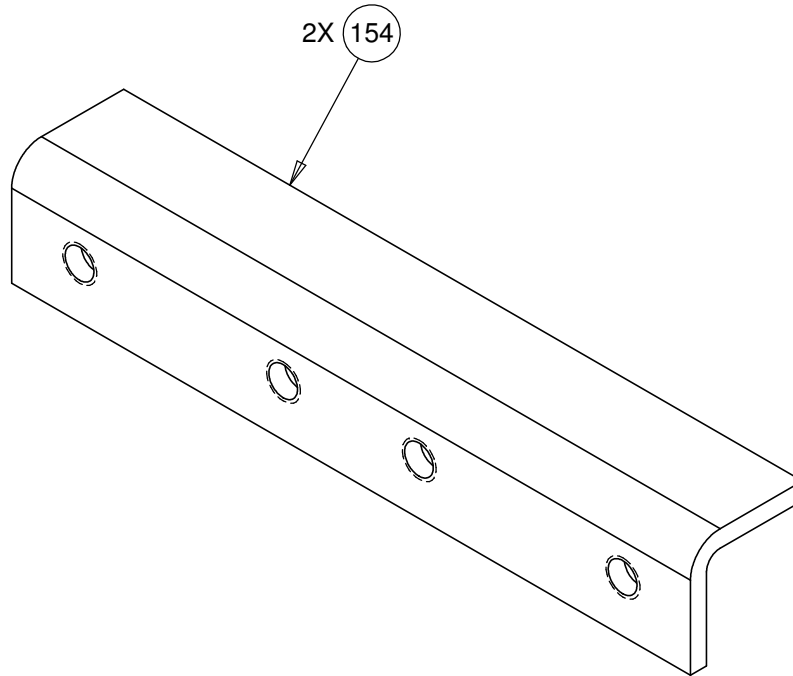

CONFIDENTIAL

THIS DOCUMENT AND INFORMATION CONTAINED HEREIN IS PROPRIETARY AND CONFIDENTIAL TO PRECOR STRENGTH INCORPORATED. RECIPIENTS OF THIS DOCUMENT AGREE THAT THIS DOCUMENT AND INFORMATION WILL NOT BE USED FOR ANY PURPOSE, REPRODUCED OR COPIED, OR DISCLOSED TO ANY THIRD PARTY, EITHER IN WHOLE OR IN PART WITHOUT PRIOR EXPRESS WRITTEN PERMISSION OF PRECOR STRENGTH INCORPORATED.

PRECOR USA
PRECOR STRENGTH, INC.

**28936 AVE WILLIAMS
VALENCIA, CA 91355
TELEPHONE: 661-362-0300**

SIGN IN BLUE OR BLACK INK ONLY			UNLESS OTHERWISE SPECIFIED: DIMENSIONS ARE IN INCHES TOLERANCES ARE:		
DRWN BY	08.27.09	VLE	LIN	.X=±0.1	.XXX=±0.010
DWG CHK			LIN	.XX=±0.02	.XXXX=±0.0001
ENG	08.27.09	VLE	ANGULAR: ±1.0°		
MFG ENG			ALL DIMS AFTER PLATING		
CS			BREAK ALL SHARP EDGES		
QA			REMOVE ALL BURRS		
			ALL ANGLES & BENDS 90°		
			DWG PER ASME Y14.5M-1994		
			DO NOT SCALE DRAWING		
			125° ALL MACHINED SURFACES		
ID			SIZE	PAGE	OF
REG			A	1	1

PRODUCT:
STRENGTH

STEEL, CHANNEL

DWG. NO. CW33293-402 SUBREV A